

TITLE

BOX GUTTER- ONE SLOPE

System

VM ZINC PLUS® DLSS  
ROOFING

Scale

1:5 @ A4

LEGEND:

LEGEND:

1. VM ZINC® PLUS Flashing strip
2. 19mm Plywood
3. VM ZINC® Double Lock Standing Seam Roofing
4. VM ZINC® Sheet clip
5. Anti-abrasive building paper
6. Galvanised steel stiffener
7. VM ZINC® PLUS Eave Flashing

Building Products- VM ZINC  
PO BOX 727 CROWS NEST  
NSW 2065

www.vnzinc.com  
Tel: (61) 02 9955 4400  
Fax: (61) 02 9955 1144

NOT A SHOP DRAWING

FOR ILLUSTRATION ONLY

While all technical information and suggestions herein are believed to be reliable and accurate, nothing stated herein is to be taken as a warranty, expressed or implied. Responsibility for review and validation remains solely with the design authority or other authority having jurisdiction.

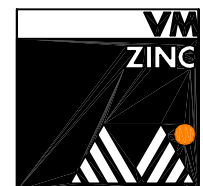

A Umicore brand

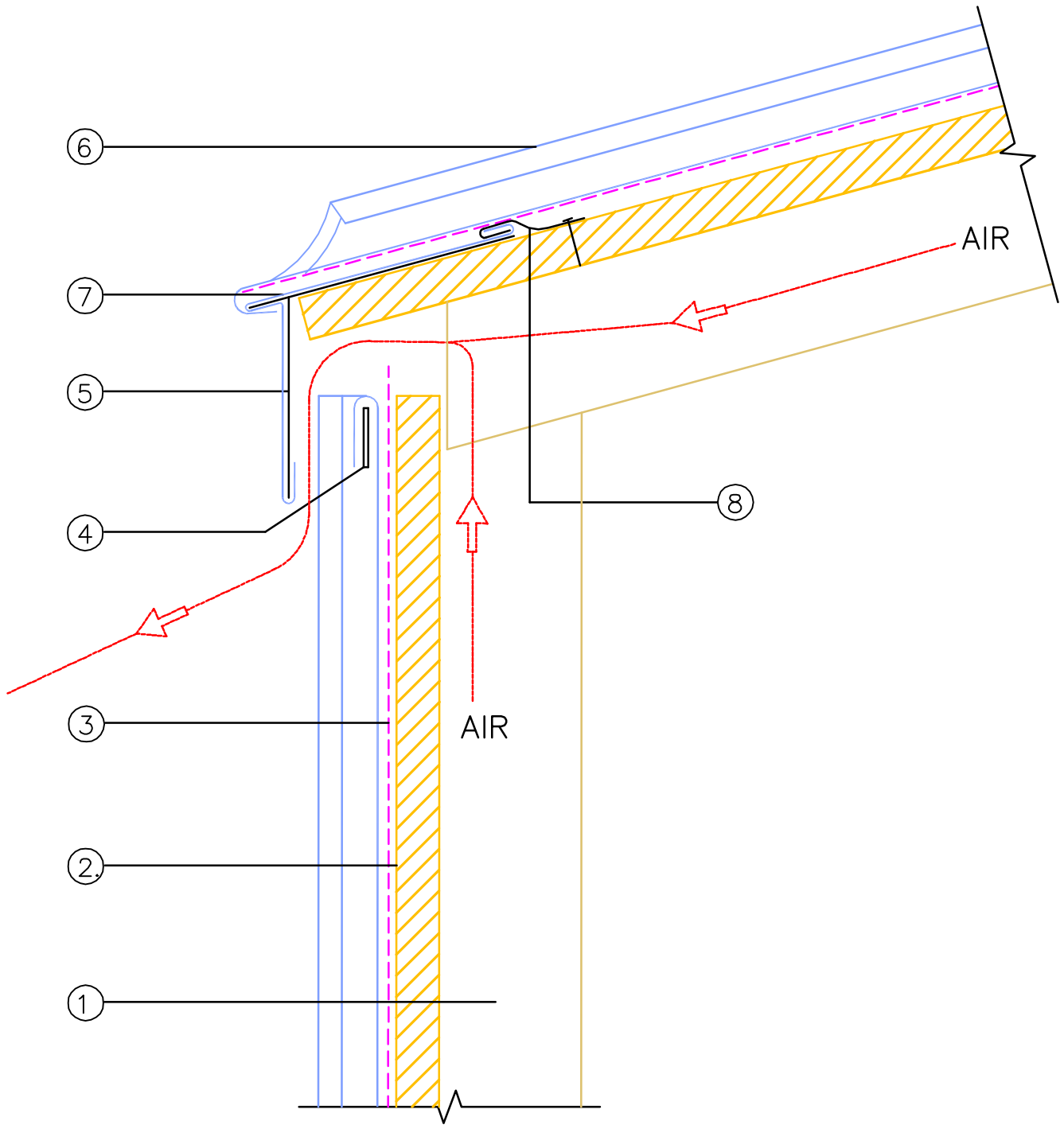

TITLE	SYSTEM	SCALE
EAVE	VM ZINC® Double Lock Standing Seam	1:25 @ A4

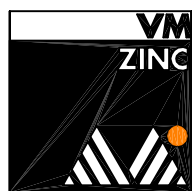
<p>LEGEND:</p> <ol style="list-style-type: none"> <li>1. Rafter for ventilation</li> <li>2. 15mm plywood</li> <li>3. Anti-abrasive building paper</li> <li>4. Galvanised steel fastener</li> <li>5. Galvanised steel stiffener</li> <li>6. VM ZINC® PLUS double lock standing seam</li> <li>7. VM ZINC® PLUS eave flashing</li> <li>8. VM ZINC® PLUS sheet clip</li> </ol>	<p>Building Products- VM ZINC            PO BOX 727 CROWS NEST            NSW 2065</p> <p><a href="http://www.vmzinc.com">www.vmzinc.com</a>            Tel: (61) 02 9955 4400            Fax: (61) 02 9955 1144</p>	<p>NOT A SHOP DRAWING</p> <hr/> <p>FOR ILLUSTRATION ONLY</p> <p>While all technical information and suggestions herein are believed to be reliable and accurate, nothing stated herein is to be taken as a warranty, expressed or implied. Responsibility for review and validation remains solely with the design authority or other authority having jurisdiction.</p>	 <p>A Umicore brand</p>
--	--	--	--

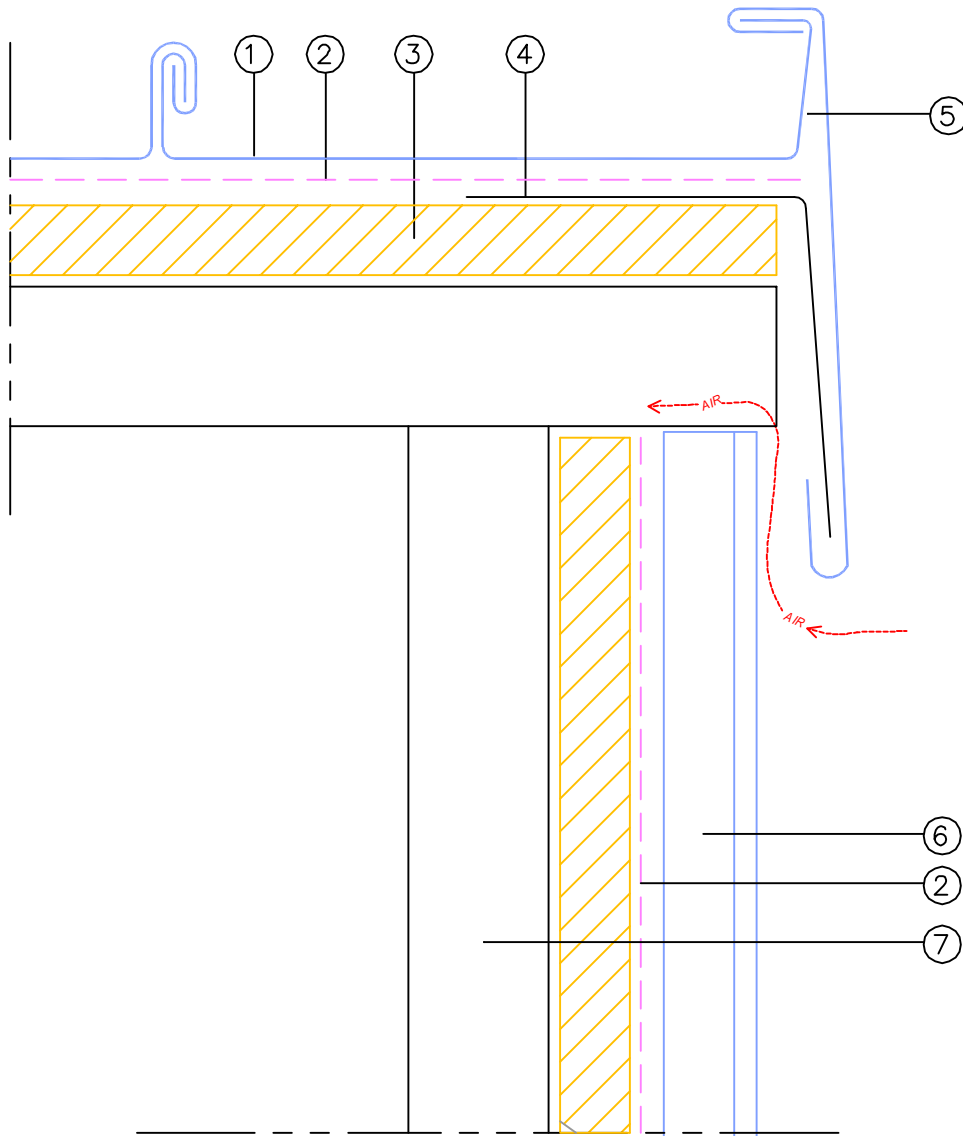

TITLE	SYSTEM	SCALE
EDGE	VM ZINC® Double Lock Standing Seam	1:2 @ A4

- LEGEND:
1. VM ZINC® PLUS double lock standing seam
  2. Anti-abrasive building paper
  3. 19mm plywood
  4. Continuous galvanized steel stiffener
  5. VM ZINC® PLUS edge flashing
  6. VM ZINC® PLUS single lock standing seam
  7. Ventilation Rafter

Building Products- VM ZINC  
 PO BOX 727 CROWS NEST  
 NSW 2065

[www.vnzinc.com](http://www.vnzinc.com)  
 Tel: (61) 02 9955 4400  
 Fax: (61) 02 9955 1144

NOT A SHOP DRAWING  
 FOR ILLUSTRATION ONLY

While all technical information and suggestions herein are believed to be reliable and accurate, nothing stated herein is to be taken as a warranty, expressed or implied. Responsibility for review and validation remains solely with the design authority or other authority having jurisdiction.

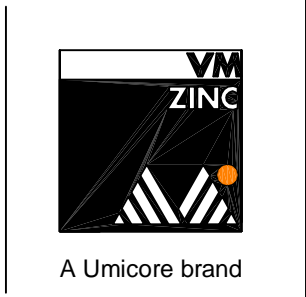

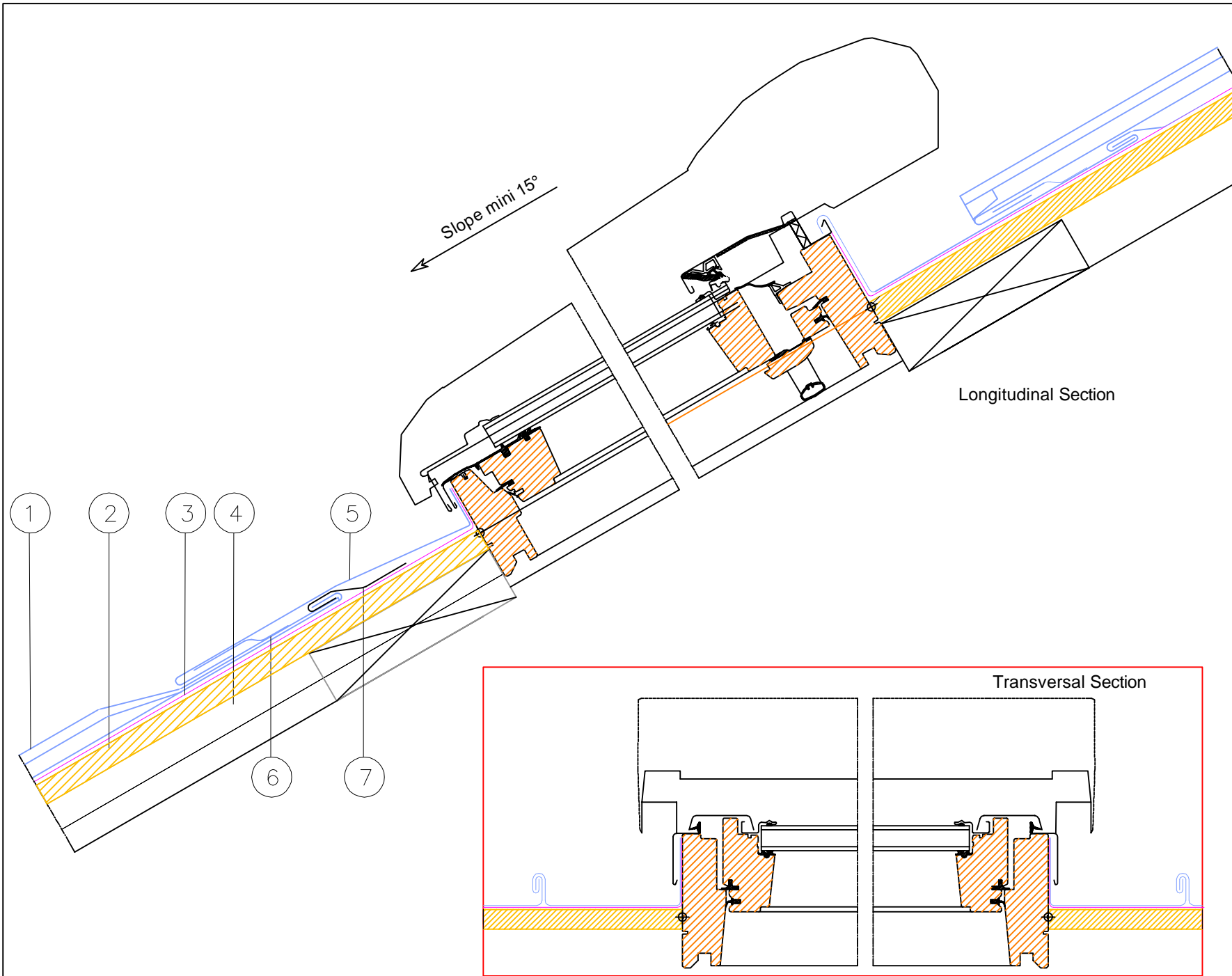

TITLE

EXTRUDED SKYLIGHT

System

VM ZINC PLUS® DLSS  
ROOFING

Scale

1:5 @ A4

LEGEND:

- LEGEND:
1. VM ZINC® PLUS Double lock standing Seam
  2. 19mm Plywood
  3. Anti -Abrasive Building Paper
  4. 40min Ventilation Air Gap
  5. VM ZINC® PLUS Flashing
  6. Soldered VM ZINC Strip
  7. Galvanised Steel sheet Clip

Building Products- VM ZINC  
PO BOX 727 CROWS NEST  
NSW 2065

www.vmezinc.com  
Tel: (61) 02 9955 4400  
Fax: (61) 02 9955 1144

NOT A SHOP DRAWING

FOR ILLUSTRATION ONLY

While all technical information and suggestions herein are believed to be reliable and accurate, nothing stated herein is to be taken as a warranty, expressed or implied. Responsibility for review and validation remains solely with the design authority or other authority having jurisdiction.



A Umicore brand