

TITLE	SYSTEM	SCALE
BOTTOM OF WALL	VM ZINC® Vertical Interlocking Panel	1:2 @ A4

- LEGEND:
1. VM ZINC Interlocking Panel
  2. Framework ( i.e. Furring Channel)
  3. VM ZINC PLUS apron flashing
  4. Galvanised steel stiffener
  5. Main structure ( by others)

Building Products- VM ZINC  
 PO BOX 727 CROWS NEST  
 NSW 2065

[www.vmzinc.com.au](http://www.vmzinc.com.au)  
 Tel: (61) 02 9955 4400  
 Fax: (61) 02 9955 1144

NOT A SHOP DRAWING  
 FOR ILLUSTRATION ONLY

While all technical information and suggestions herein are believed to be reliable and accurate, nothing stated herein is to be taken as a warranty, expressed or implied. Responsibility for review and validation remains solely with the design authority or other authority having jurisdiction.

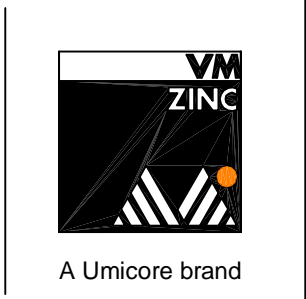

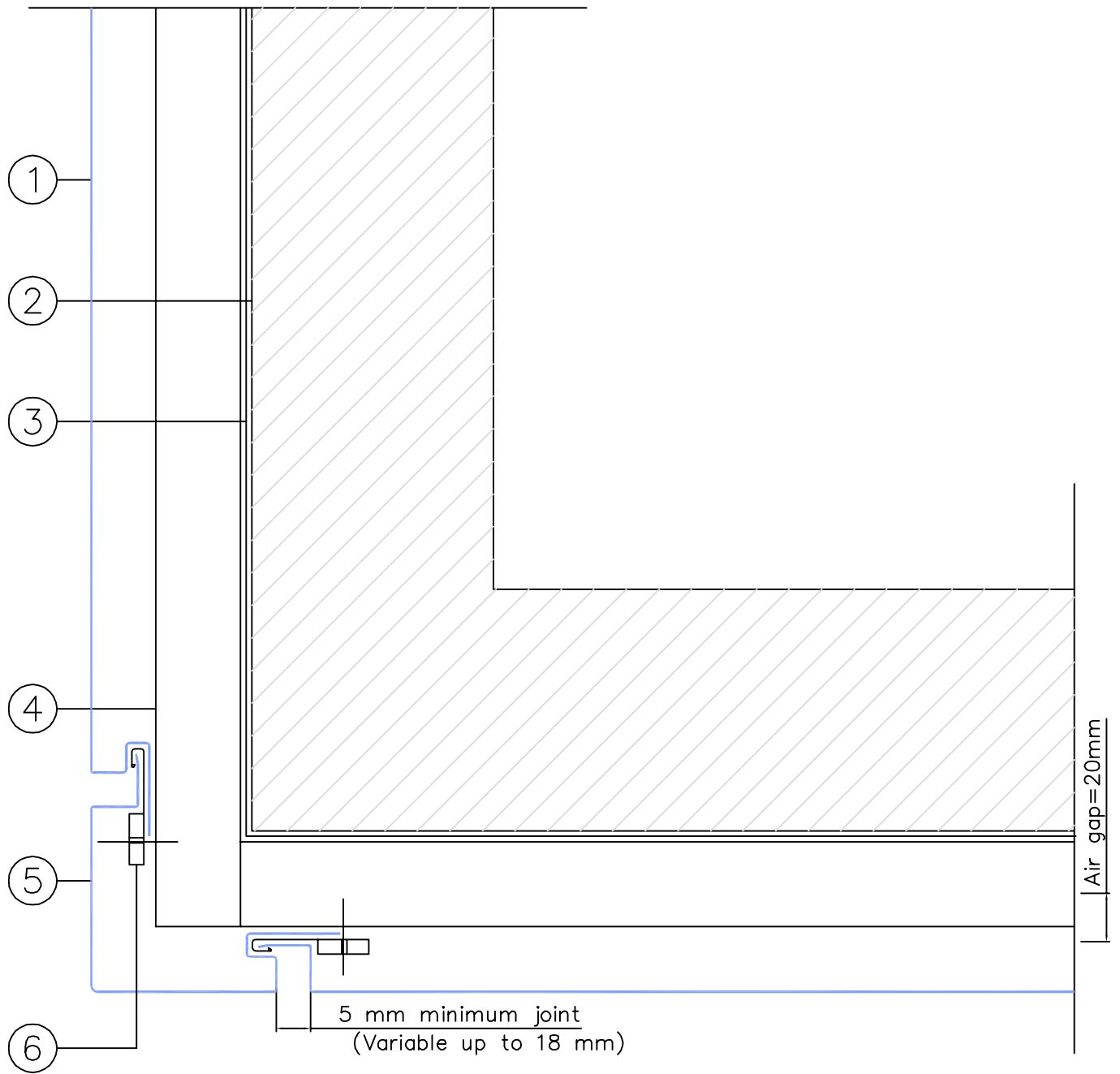

TITLE	SYSTEM	SCALE
EXTERIOR CORNER	VM ZINC® Vertical Interlocking Panel	1:25 @ A4

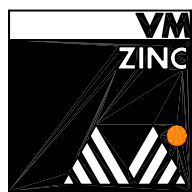
<p>LEGEND:</p> <ol style="list-style-type: none"> <li>1. VM ZINC Interlocking panel</li> <li>2. Main structure ( by others)</li> <li>3. Water- proof membrane</li> <li>4. Furring Channel</li> <li>5. VM ZINC exterior corner</li> <li>6. VM ZINC Interlocking panel clip</li> </ol>	<p>Building Products- VM ZINC          PO BOX 727 CROWS NEST          NSW 2065</p> <p><a href="http://www.vmzinc.com.au">www.vmzinc.com.au</a>          Tel: (61) 02 9955 4400          Fax: (61) 02 9955 1144</p>	<p>NOT A SHOP DRAWING          FOR ILLUSTRATION ONLY</p> <p>While all technical information and suggestions herein are believed to be reliable and accurate, nothing stated herein is to be taken as a warranty, expressed or implied. Responsibility for review and validation remains solely with the design authority or other authority having jurisdiction.</p>	 <p>A Umicore brand</p>
--	--	--	--

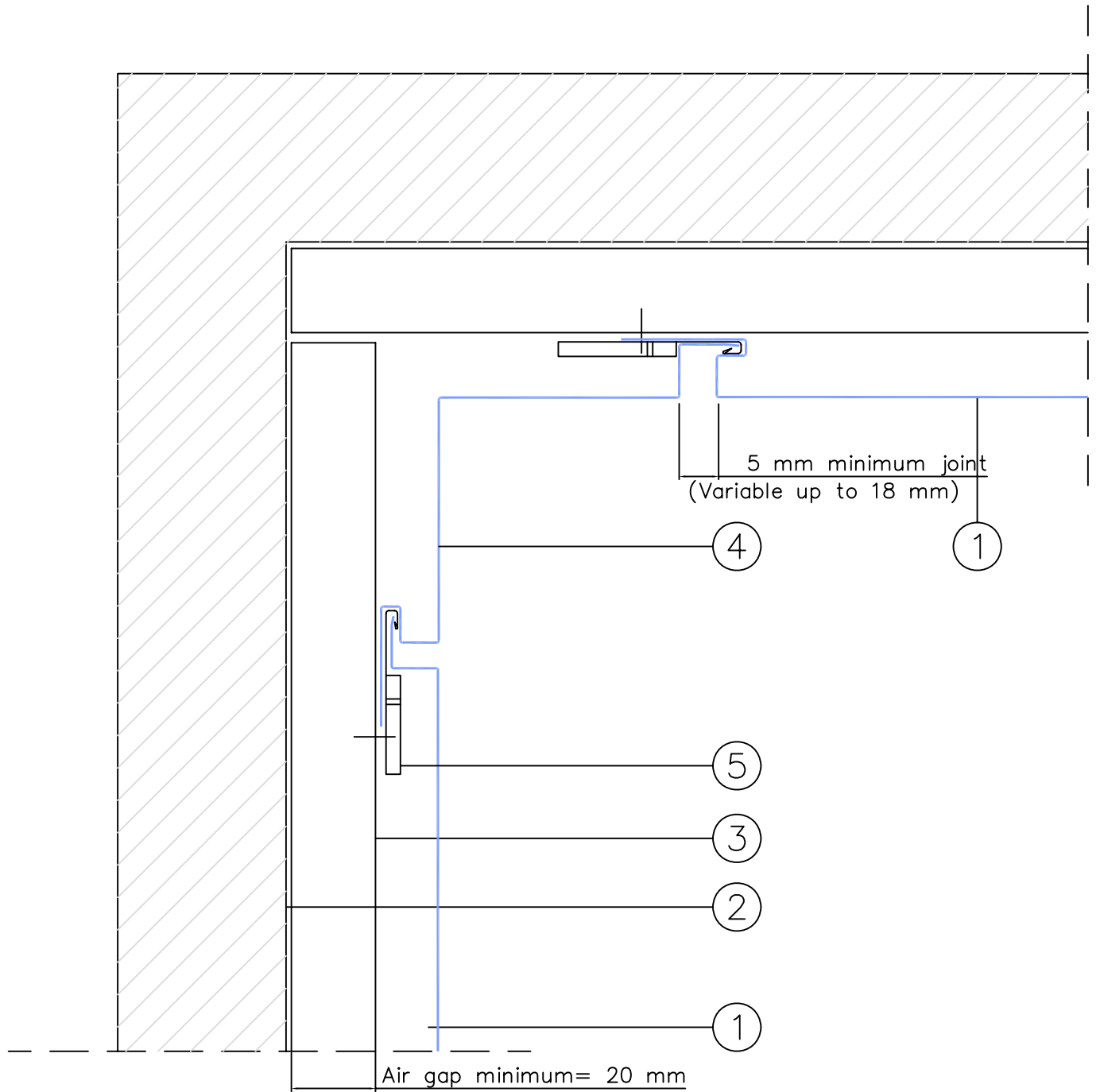

TITLE

SYSTEM

SCALE

INTERIOR CORNER

VM ZINC® Vertical Interlocking Panel

1:25 @ A4

LEGEND:

1. VM ZINC Interlocking Panel
2. Furring Channel
3. VM ZINC Flat inverted slider
4. Main Structure

Building Products- VM ZINC  
PO BOX 727 CROWS NEST  
NSW 2065

www.vmzinc.com.au  
Tel: (61) 02 9955 4400  
Fax: (61) 02 9955 1144

NOT A SHOP DRAWING

FOR ILLUSTRATION ONLY

While all technical information and suggestions herein are believed to be reliable and accurate, nothing stated herein is to be taken as a warranty, expressed or implied. Responsibility for review and validation remains solely with the design authority or other authority having jurisdiction.



A Umicore brand

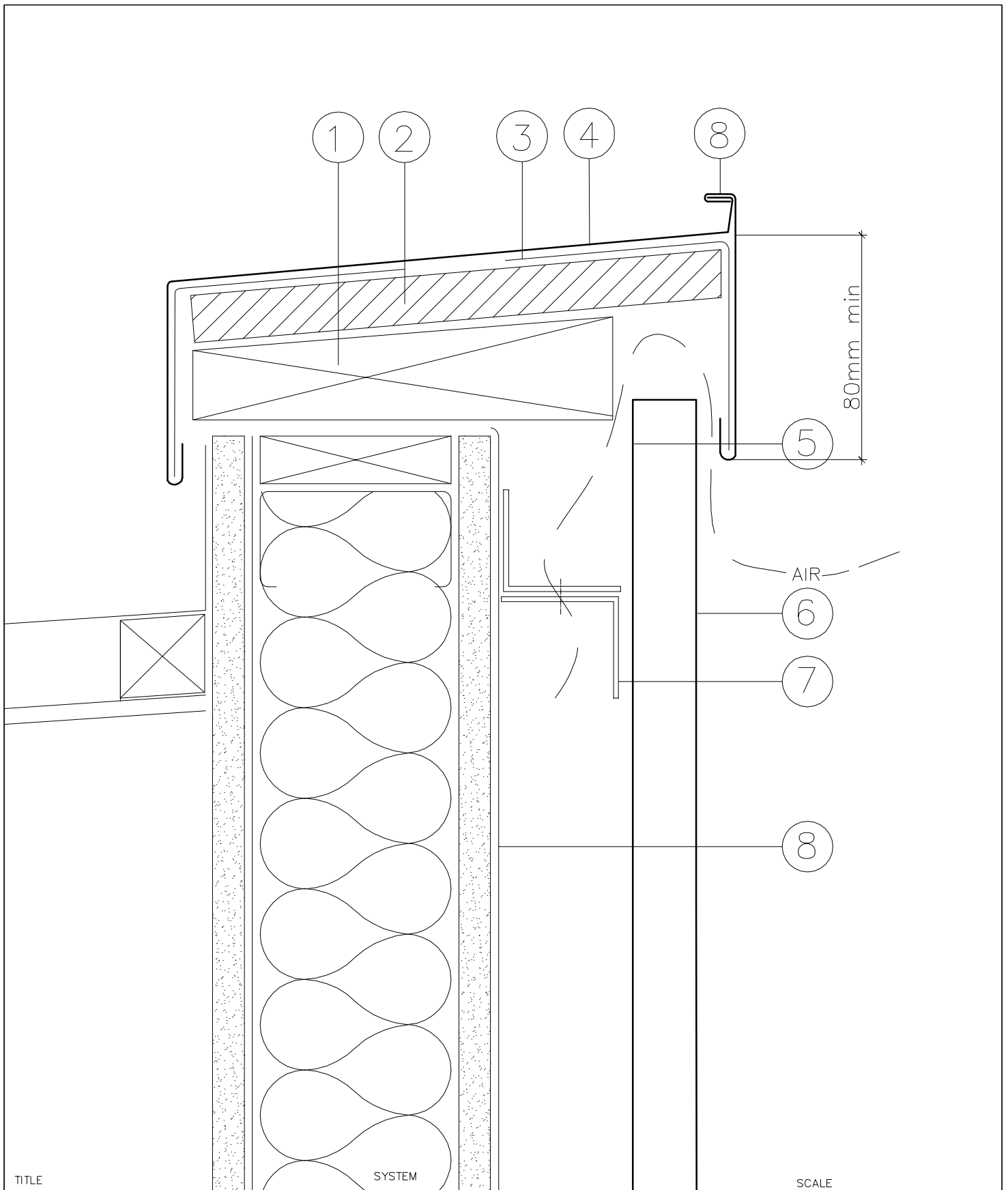

TITLE

SYSTEM

SCALE

PARAPET WITH SLIDER/ FASCIA CAPPING

VM ZINC® INTERLOCKING PANEL

1:2 @ A4

LEGEND:

1. Blocking
2. 15 mm Plywood
3. Galvanised stiffener
4. VM ZINC PLUS parapet Flashing 0.7
5. Insect screen if needed
6. VM ZINC Interlocking panel vertical laying
7. Furring Channel
8. Water proof membrane
9. VM ZINC 1.0mm Fascia Flashing

Building Products- VM ZINC  
PO BOX 727 CROWS NEST  
NSW 2065

[www.vnzinc.com.au](http://www.vnzinc.com.au)  
Tel: (61) 02 9955 4400  
Fax: (61) 02 9955 1144

NOT A SHOP DRAWING

FOR ILLUSTRATION ONLY

While all technical information and suggestions herein are believed to be reliable and accurate, nothing stated herein is to be taken as a warranty, expressed or implied. Responsibility for review and validation remains solely with the design authority or other authority having jurisdiction.



A Umicore brand

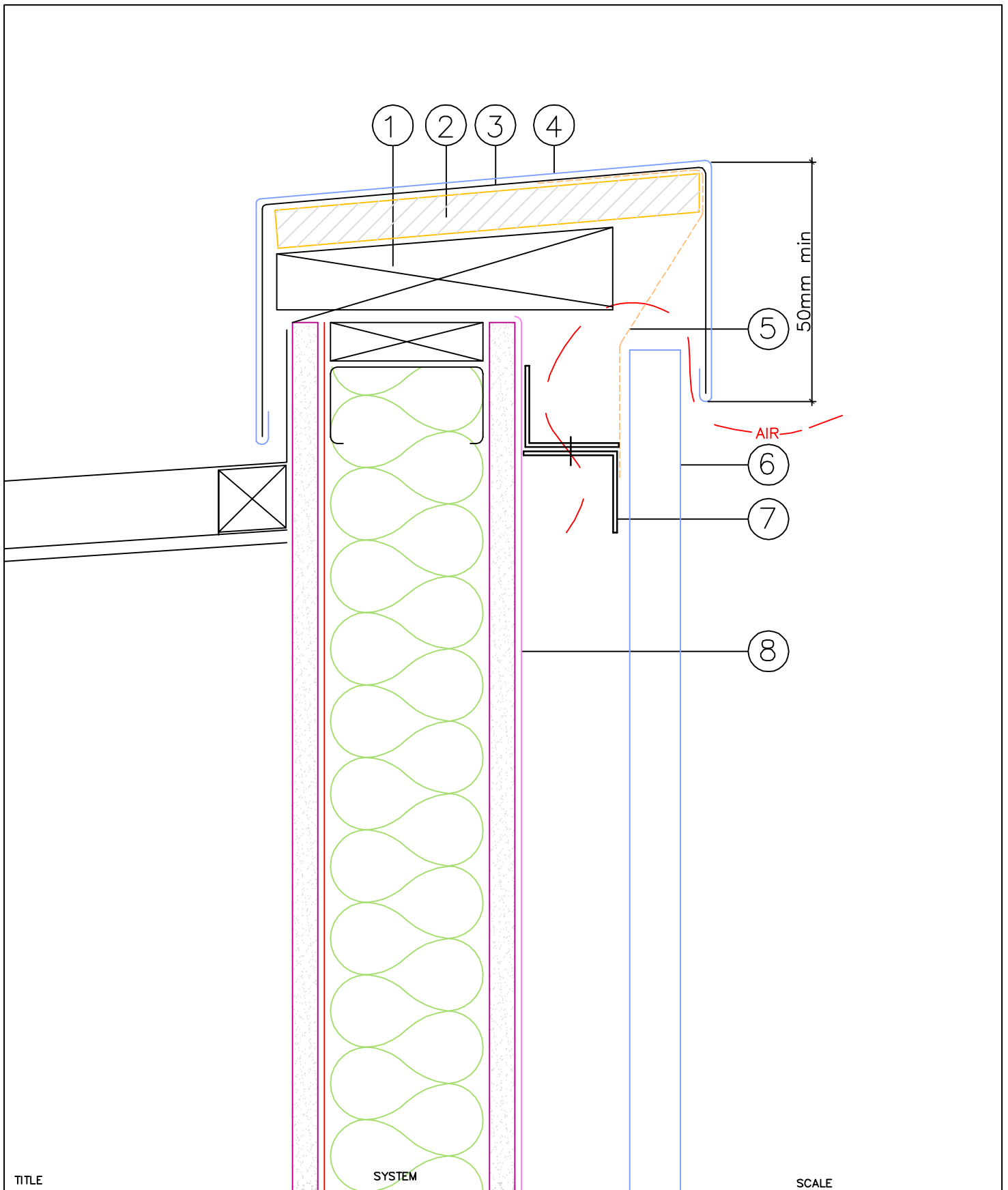

TITLE

SYSTEM

SCALE

PARAPET

VM ZINC® Vertical Interlocking Panel

1:25 @ A4

LEGEND:

1. Blocking
2. 19mm Plywood
3. Continuous galvanised steel stiffener
4. VM ZINC PLUS parapet capping
5. Insect screen ( if needed)
6. VM ZINC interlocking panel
7. Furring Channel
8. Water proof membrane

Building Products- VM ZINC  
PO BOX 727 CROWS NEST  
NSW 2065

[www.vmpzinc.com.au](http://www.vmpzinc.com.au)  
Tel: (61) 02 9955 4400  
Fax: (61) 02 9955 1144

NOT A SHOP DRAWING

FOR ILLUSTRATION ONLY

While all technical information and suggestions herein are believed to be reliable and accurate, nothing stated herein is to be taken as a warranty, expressed or implied. Responsibility for review and validation remains solely with the design authority or other authority having jurisdiction.

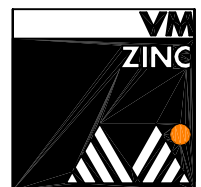

A Umicore brand

## Window Head

## Window Sill

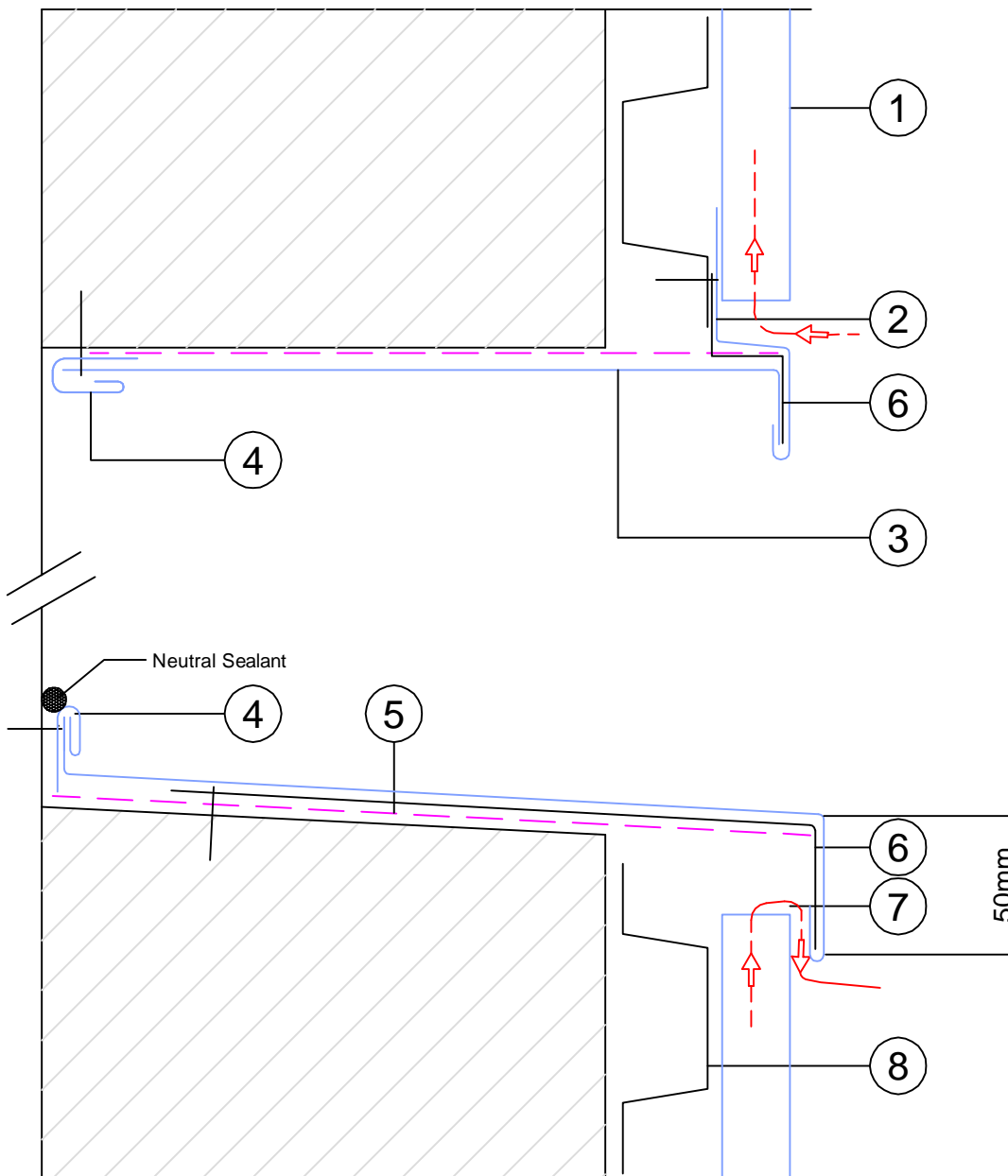

TITLE

SYSTEM

SCALE

RECESSED WINDOW HEAD & SILL

VM ZINC® Vertical Interlocking Panel

1:25 @ A4

LEGEND:

1. VM ZINC Interlocking Panel
2. VM ZINC PLUS Apron flashing
3. VM ZINC PLUS perforated bottom flashing
4. VM ZINC PLUS folded end flashing
5. Anti- abrasive building paper
6. Galvanised steel stiffener
7. VM ZINC PLUS window sill flashing
8. Furring channel

Building Products- VM ZINC  
PO BOX 727 CROWS NEST  
NSW 2065

[www.vmezinc.com.au](http://www.vmezinc.com.au)  
Tel: (61) 02 9955 4400  
Fax: (61) 02 9955 1144

NOT A SHOP DRAWING

FOR ILLUSTRATION ONLY

While all technical information and suggestions herein are believed to be reliable and accurate, nothing stated herein is to be taken as a warranty, expressed or implied. Responsibility for review and validation remains solely with the design authority or other authority having jurisdiction.

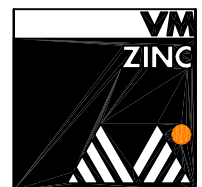

A Umicore brand

TITLE

WINDOW JAMB

System

VM ZINC® Vertical Interlocking  
Panel

Scale

1:25 @ A4

LEGEND:

LEGEND:

1. VM ZINC Interlocking panel
2. VM ZINC Folded flashing strip
3. Window
4. Furring channel

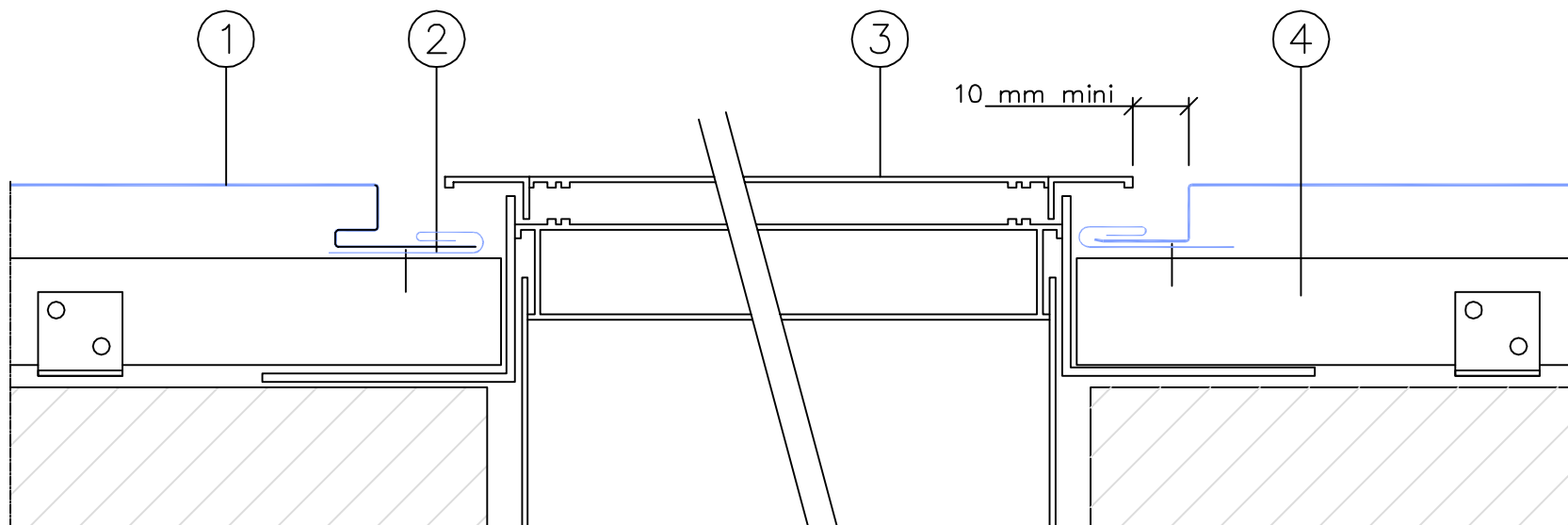

Building Products- VM ZINC  
PO BOX 727 CROWS NEST  
NSW 2065

www.v zinc.com.au  
Tel: (61) 02 9955 4400  
Fax: (61) 02 9955 1144

NOT A SHOP DRAWING

FOR ILLUSTRATION ONLY

While all technical information and suggestions herein are believed to be reliable and accurate, nothing stated herein is to be taken as a warranty, expressed or implied. Responsibility for review and validation remains solely with the design authority or other authority having jurisdiction.



A Umicore brand

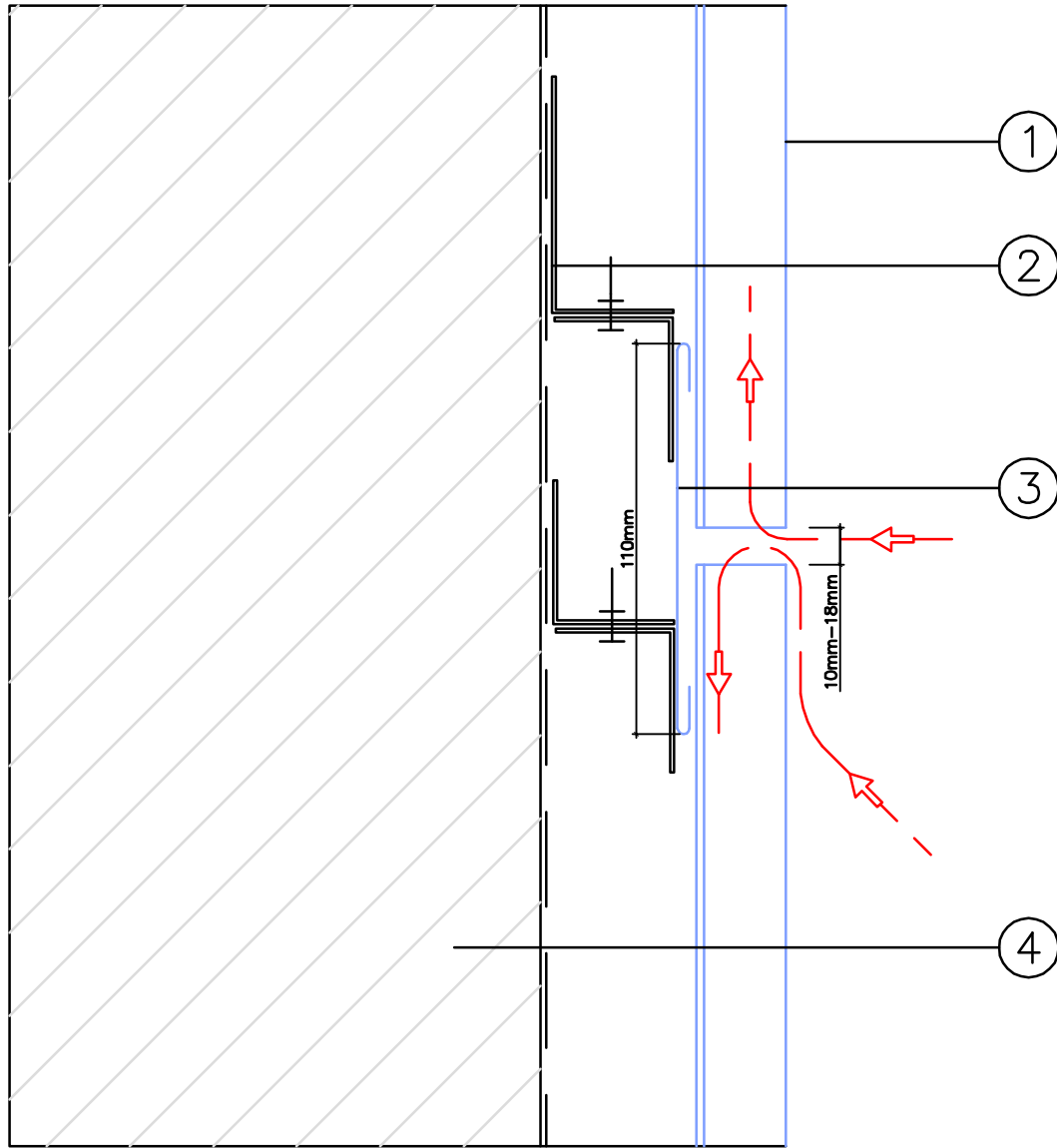

TITLE

SYSTEM

SCALE

TRANVERSAL JUNCTION

VM ZINC® Vertical Interlocking Panel

1:2 @ A4

LEGEND:

1. VM ZINC Interlocking panel
2. Furring Channel
3. VM ZINC Fast inverted slider
4. Main Structure

Building Products- VM ZINC  
PO BOX 727 CROWS NEST  
NSW 2065

[www.vmezinc.com.au](http://www.vmezinc.com.au)  
Tel: (61) 02 9955 4400  
Fax: (61) 02 9955 1144

NOT A SHOP DRAWING

FOR ILLUSTRATION ONLY

While all technical information and suggestions herein are believed to be reliable and accurate, nothing stated herein is to be taken as a warranty, expressed or implied. Responsibility for review and validation remains solely with the design authority or other authority having jurisdiction.

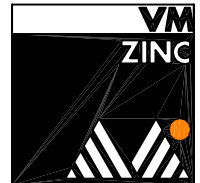

A Umicore brand

CLIP  
1:5

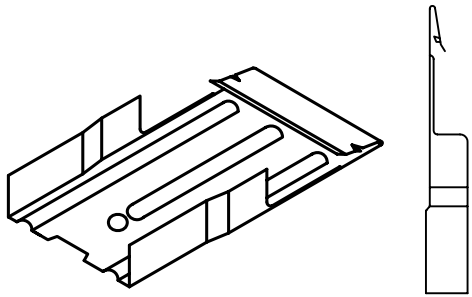

GROOVED JOINT

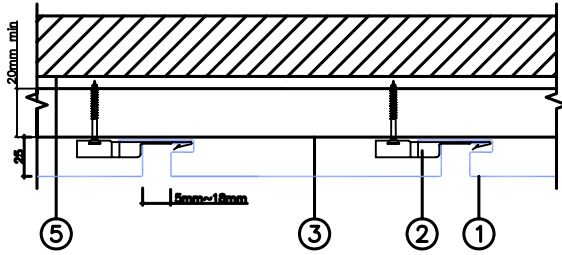

TRANSVERSAL JOINT

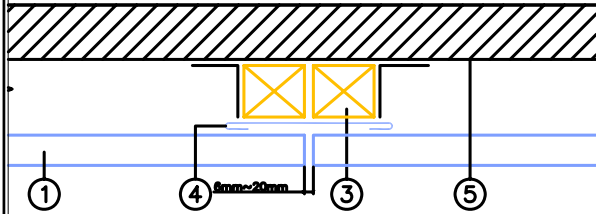

PANEL SECTION  
1:2

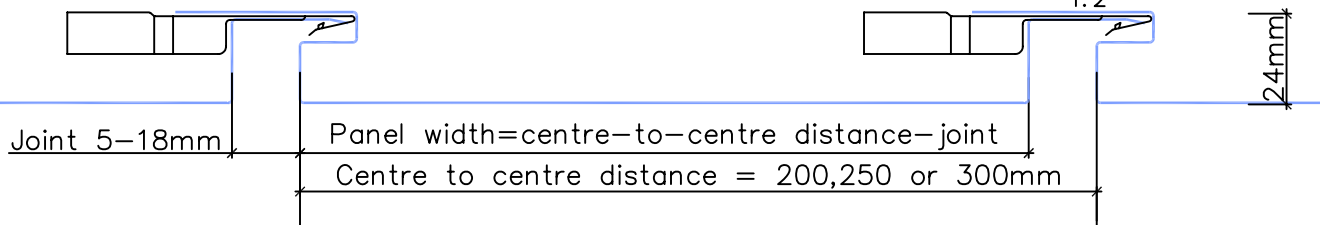

TITLE

TYPICAL DETAILS

System

VM ZINC ® INTERLOCKING  
PANEL

Scale

VARIES @ A4

LEGEND:

LEGEND:

1. VM ZINC Interlocking Panel
2. VM ZINC Interlocking panel clip
3. Furring Channel
4. VM ZINC Flat inverted slider
5. Main Structure (by others)

Building Products- VM ZINC  
PO BOX 727 CROWS NEST  
NSW 2065

www.v zinc.com.au  
Tel: (61) 02 9955 4400  
Fax: (61) 02 9955 1144

NOT A SHOP DRAWING

FOR ILLUSTRATION ONLY

While all technical information and suggestions herein are believed to be reliable and accurate, nothing stated herein is to be taken as a warranty, expressed or implied. Responsibility for review and validation remains solely with the design authority or other authority having jurisdiction.

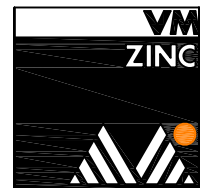

A Umicore brand