

TITLE

SYSTEM

SCALE

EXTERIOR CORNER

VM ZINC® Horizontal Interlocking Panel

1:25 @ A4

LEGEND:

1. VM ZINC Interlocking panel
2. Main structure (by others)
3. Furring channel
4. VM ZINC Interlocking panel Exterior Corner
5. Waterproof membrane

Building Products- VM ZINC
PO BOX 727 CROWS NEST
NSW 2065

www.vmpzinc.com.au
Tel: (61) 02 9955 4400
Fax: (61) 02 9955 1144

NOT A SHOP DRAWING

FOR ILLUSTRATION ONLY

While all technical information and suggestions herein are believed to be reliable and accurate, nothing stated herein is to be taken as a warranty, expressed or implied. Responsibility for review and validation remains solely with the design authority or other authority having jurisdiction.

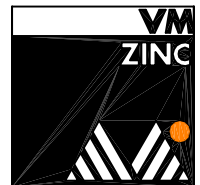

A Umicore brand

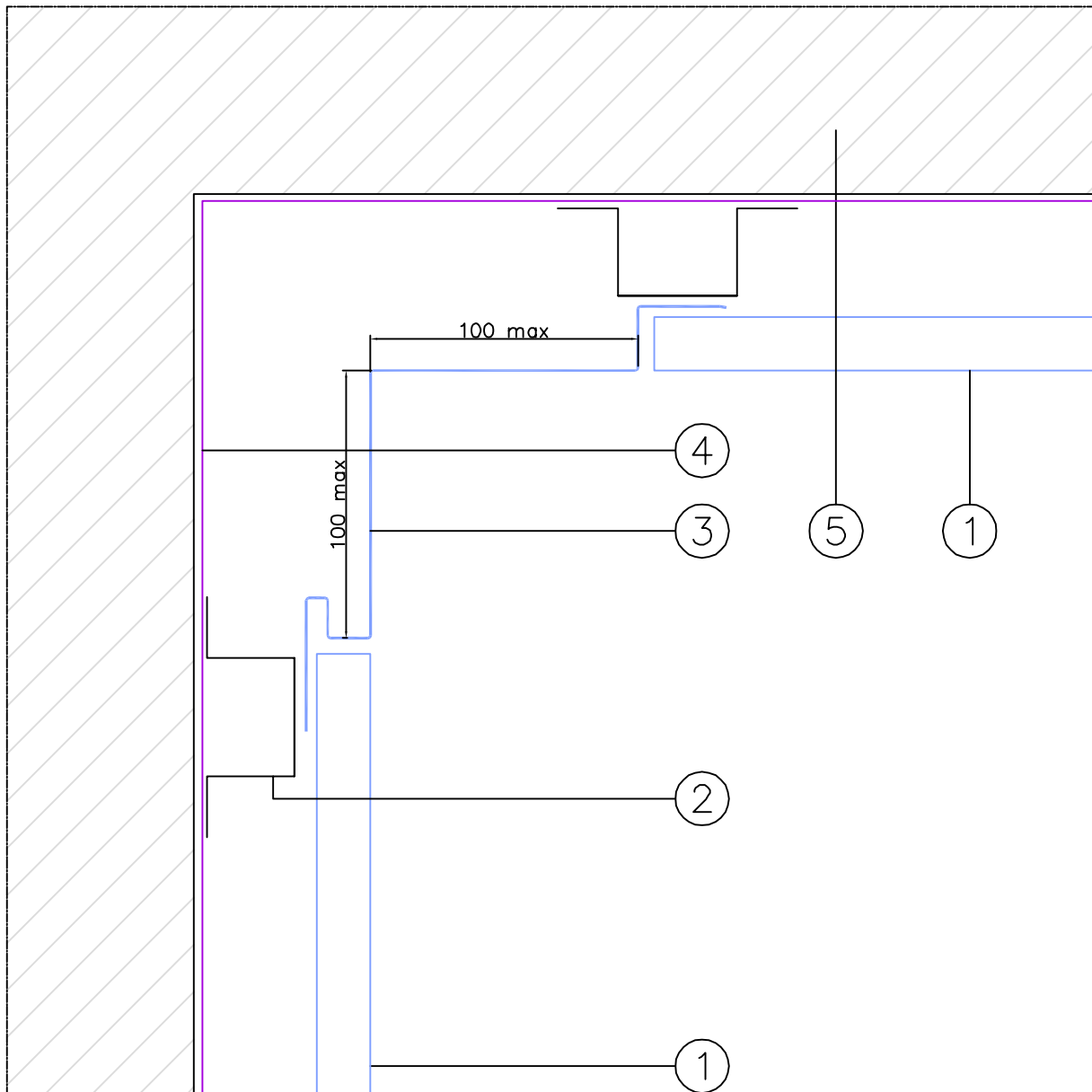

TITLE	SYSTEM	SCALE
INTERIOR CORNER	VM ZINC® Horizontal Interlocking Panel	1:25 @ A4

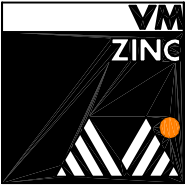
<p>LEGEND:</p> <ol style="list-style-type: none"> 1. VM ZINC Interlocking panel 2. Furring channel 3. VM ZINC Interlocking panel interior corner 4. Waterproof membrane 5. Main structure (by others) 	<p>Building Products- VM ZINC PO BOX 727 CROWS NEST NSW 2065</p> <p>www.vmpzinc.com.au Tel: (61) 02 9955 4400 Fax: (61) 02 9955 1144</p>	<p>NOT A SHOP DRAWING FOR ILLUSTRATION ONLY</p> <p>While all technical information and suggestions herein are believed to be reliable and accurate, nothing stated herein is to be taken as a warranty, expressed or implied. Responsibility for review and validation remains solely with the design authority or other authority having jurisdiction.</p>	 <p>A Umicore brand</p>
---	--	---	--

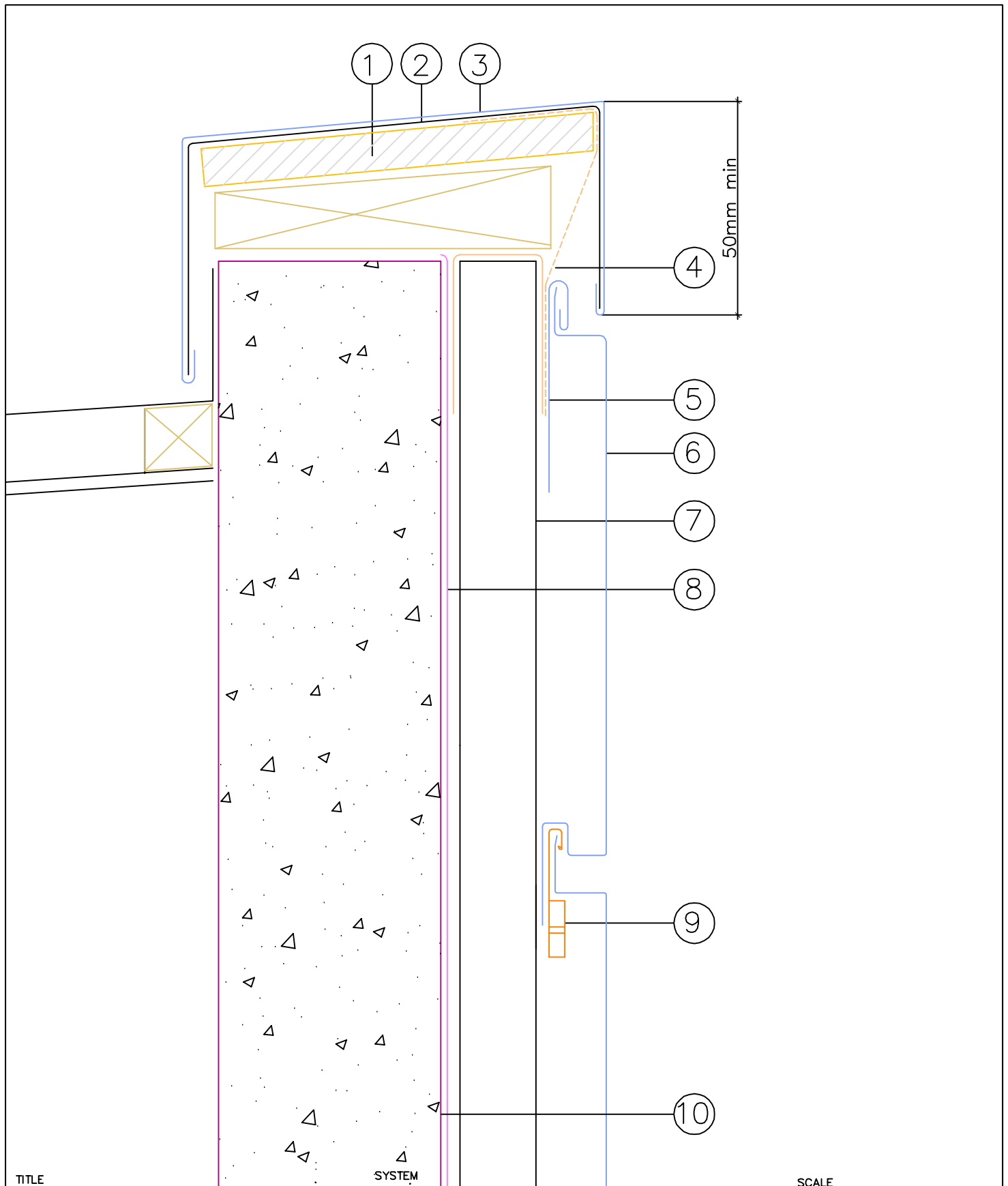

TITLE PARAPET	SYSTEM VM ZINC® Horizontal Interlocking Panel	SCALE 1:25 @ A4
-------------------------	---	---------------------------

- LEGEND:
1. 19mm Plywood
 2. Continuous galvanised steel stiffener
 3. VM ZINC PLUS parapet capping
 4. Insect screen
 5. VM ZINC folding flashing strip
 6. VM ZINC Interlocking panel
 7. Furring Channel
 8. Waterproof membrane
 9. VM ZINC Interlocking panel clip
 10. Main structure (by others)

Building Products- VM ZINC
 PO BOX 727 CROWS NEST
 NSW 2065

www.v zinc.com.au
 Tel: (61) 02 9955 4400
 Fax: (61) 02 9955 1144

NOT A SHOP DRAWING
 FOR ILLUSTRATION ONLY

While all technical information and suggestions herein are believed to be reliable and accurate, nothing stated herein is to be taken as a warranty, expressed or implied. Responsibility for review and validation remains solely with the design authority or other authority having jurisdiction.



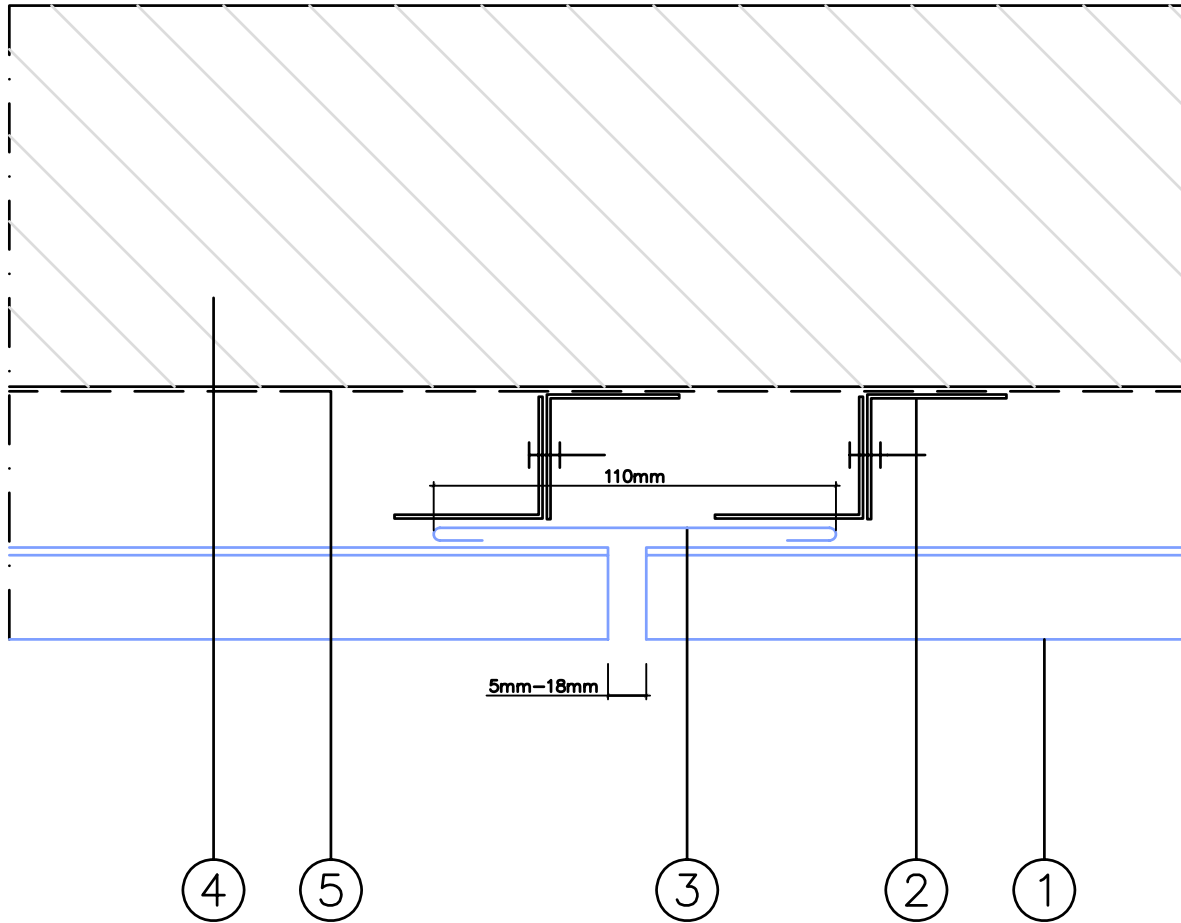

TITLE

SYSTEM

SCALE

TRANSVERSAL JUNCTION

VM ZINC® Horizontal Interlocking Panel

1:2 @ A4

LEGEND:

1. VM ZINC Interlocking Panel
2. Furring channel
3. Flat inverted slider
4. Main structure (by others)
5. Waterproof membrane

Building Products- VM ZINC
PO BOX 727 CROWS NEST
NSW 2065

www.vmezinc.com.au
Tel: (61) 02 9955 4400
Fax: (61) 02 9955 1144

NOT A SHOP DRAWING

FOR ILLUSTRATION ONLY

While all technical information and suggestions herein are believed to be reliable and accurate, nothing stated herein is to be taken as a warranty, expressed or implied. Responsibility for review and validation remains solely with the design authority or other authority having jurisdiction.

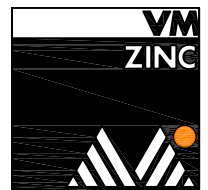

A Umicore brand

Window Head

Window Sill

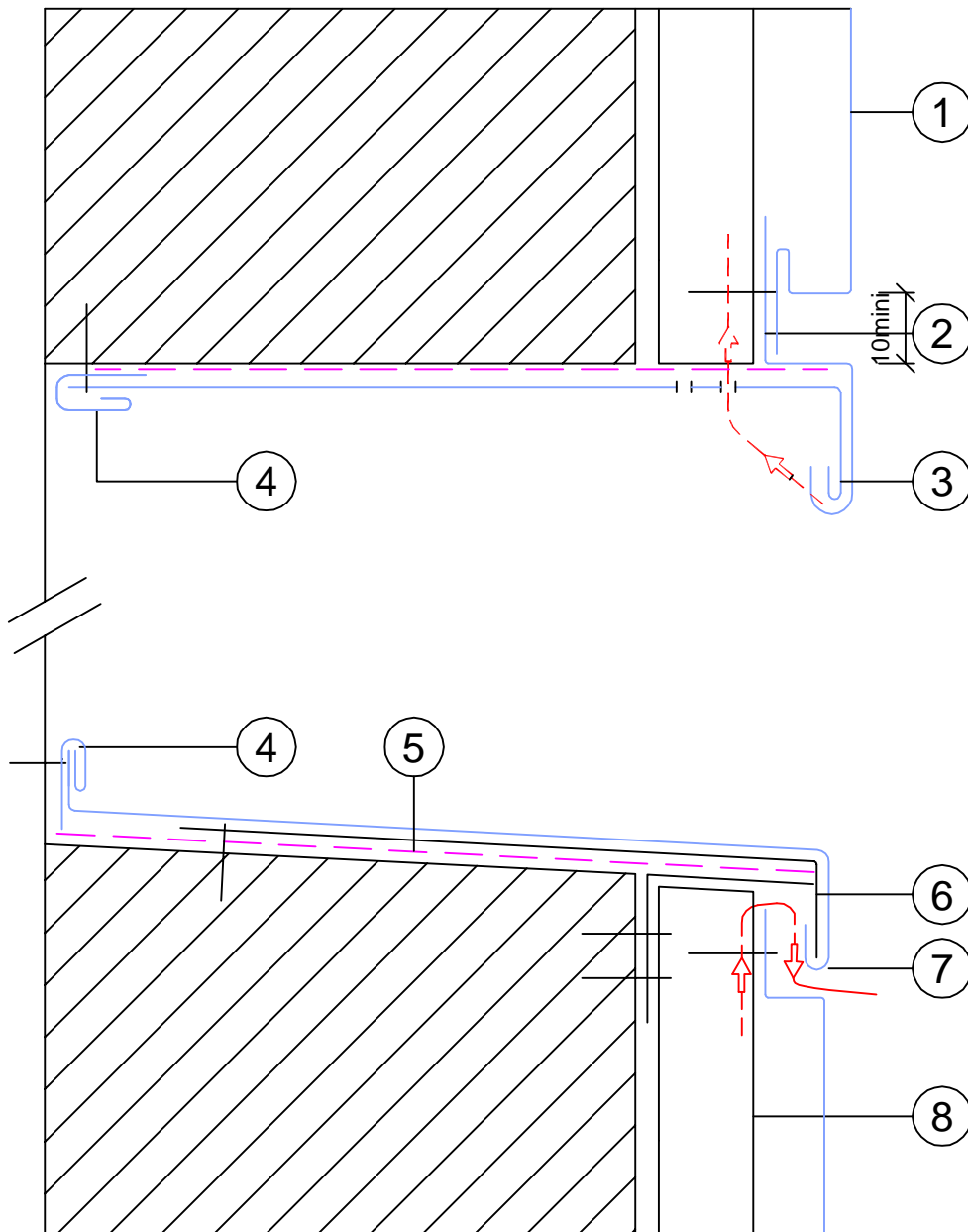

TITLE

SYSTEM

SCALE

WINDOW SILL & HEAD

VM ZINC® Horizontal Interlocking Panel

1:25 @ A4

LEGEND:

1. VM ZINC Interlocking panel
2. VM ZINC PLUS Apron flashing
3. VM ZINC Opening surround panel
4. Folded flashing strip
5. Anti-abrasive building paper
6. Galvanised steel stiffener
7. VM ZINC window support flashing
8. Furring channel

Building Products- VM ZINC
PO BOX 727 CROWS NEST
NSW 2065

www.vmzinc.com.au
Tel: (61) 02 9955 4400
Fax: (61) 02 9955 1144

NOT A SHOP DRAWING

FOR ILLUSTRATION ONLY

While all technical information and suggestions herein are believed to be reliable and accurate, nothing stated herein is to be taken as a warranty, expressed or implied. Responsibility for review and validation remains solely with the design authority or other authority having jurisdiction.

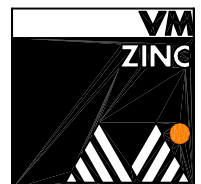

A Umicore brand

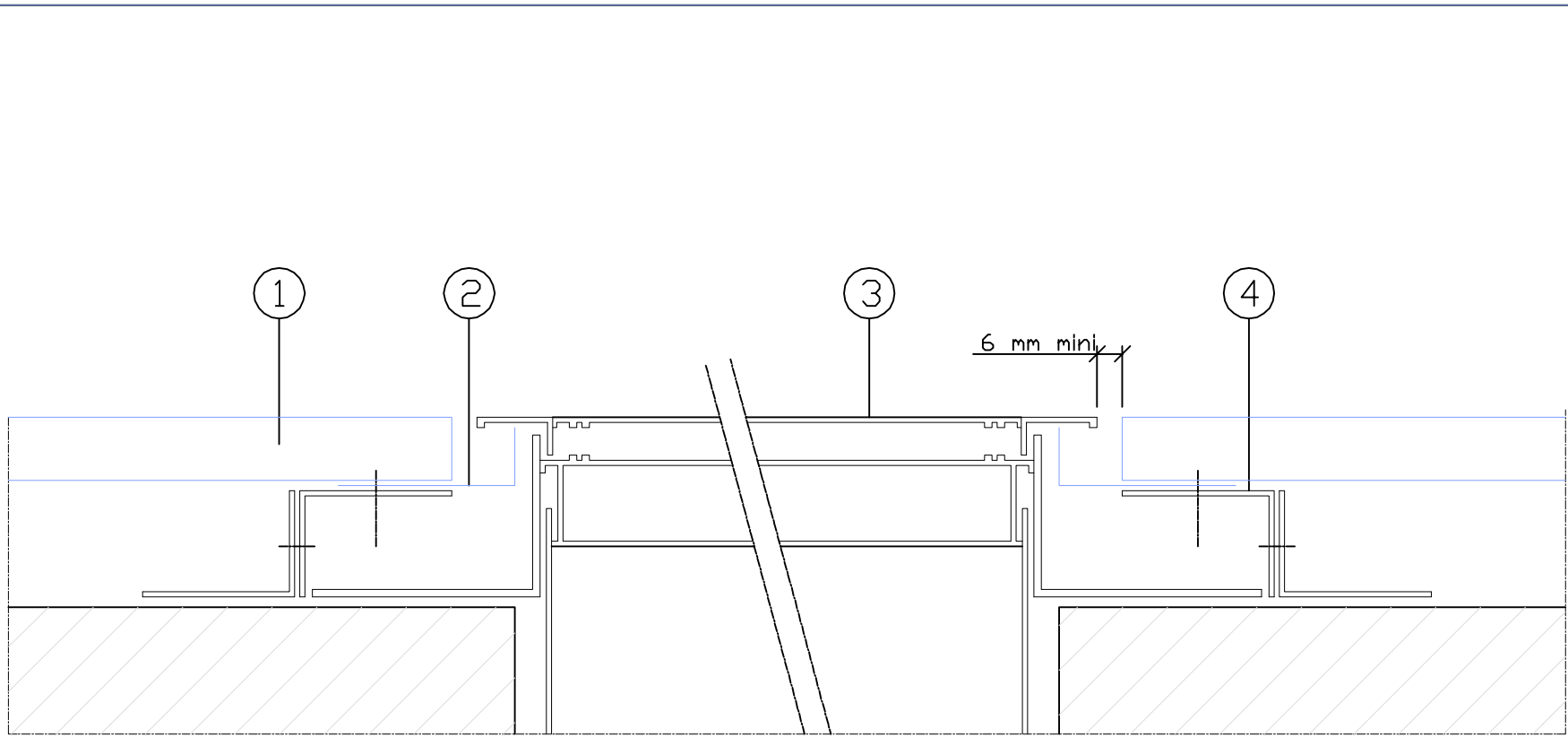

TITLE

WINDOW JAMB

System

VM ZINC® Horizontal Interlocking Panel

Scale

1:2 @ A4

LEGEND:

- LEGEND:
1. VM ZINC Interlocking panel
 2. Flashing to fold on site
 3. Window
 4. Furring channel

Building Products- VM ZINC
 PO BOX 727 CROWS NEST
 NSW 2065

www.vmzinc.com.au
 Tel: (61) 02 9955 4400
 Fax: (61) 02 9955 1144

NOT A SHOP DRAWING

FOR ILLUSTRATION ONLY

While all technical information and suggestions herein are believed to be reliable and accurate, nothing stated herein is to be taken as a warranty, expressed or implied. Responsibility for review and validation remains solely with the design authority or other authority having jurisdiction.

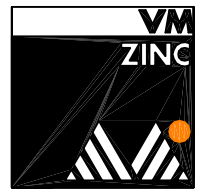

A Umicore brand

CLIP
1:5

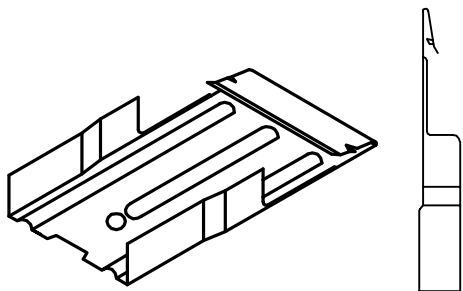

GROOVED JOINT

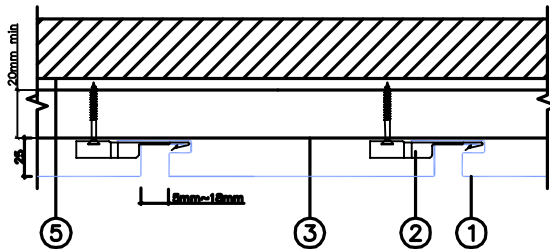

TRANSVERSAL JOINT

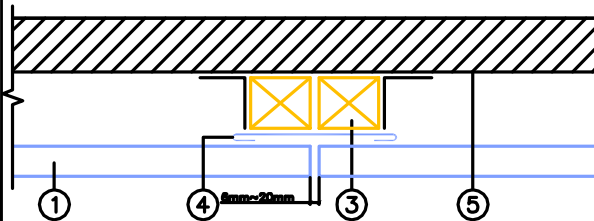

PANEL SECTION
1:2

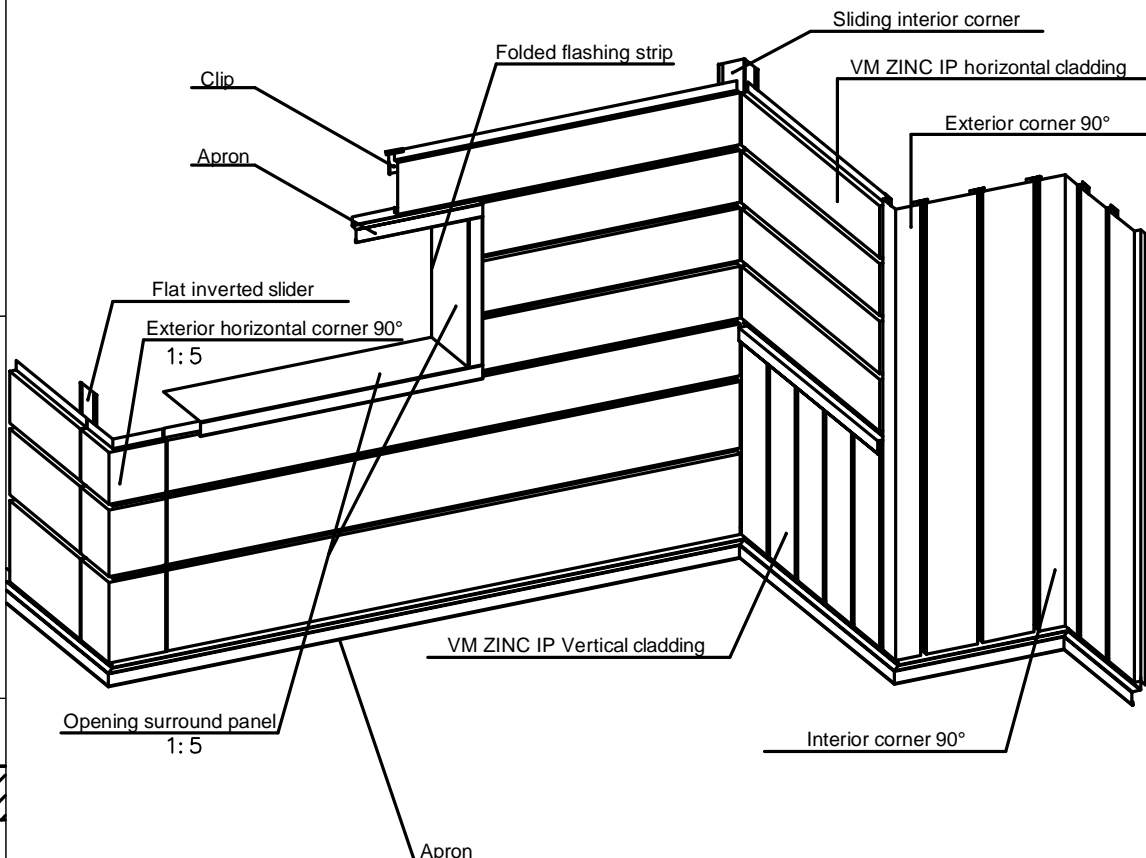
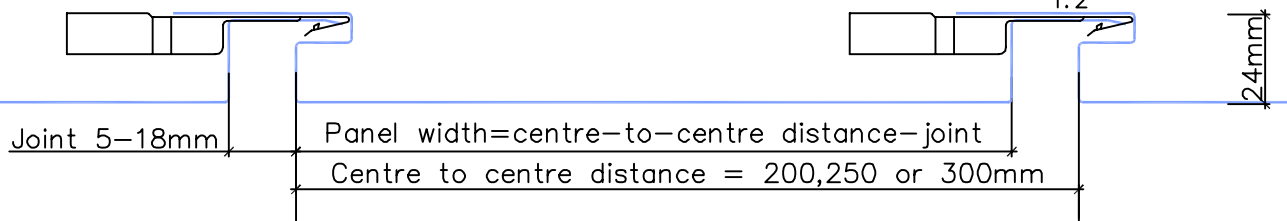

TITLE

TYPICAL DETAILS

System

VM ZINC ® INTERLOCKING
PANEL

Scale

VARIES @ A4

LEGEND:

LEGEND:

1. VM ZINC Interlocking Panel
2. VM ZINC Interlocking panel clip
3. Furring Channel
4. VM ZINC Flat inverted slider
5. Main Structure (by others)

Building Products- VM ZINC
PO BOX 727 CROWS NEST
NSW 2065

www.v zinc.com.au
Tel: (61) 02 9955 1140
Fax: (61) 02 9955 1144

GENERAL VIEW

NOT A SHOP DRAWING

FOR ILLUSTRATION ONLY

While all technical information and suggestions herein are believed to be reliable and accurate, nothing stated herein is to be taken as a warranty, expressed or implied. Responsibility for review and validation remains solely with the design authority or other authority having jurisdiction.

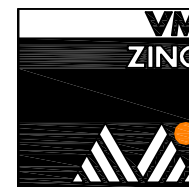

A Umicore brand