

PANEL DETAIL 1:8

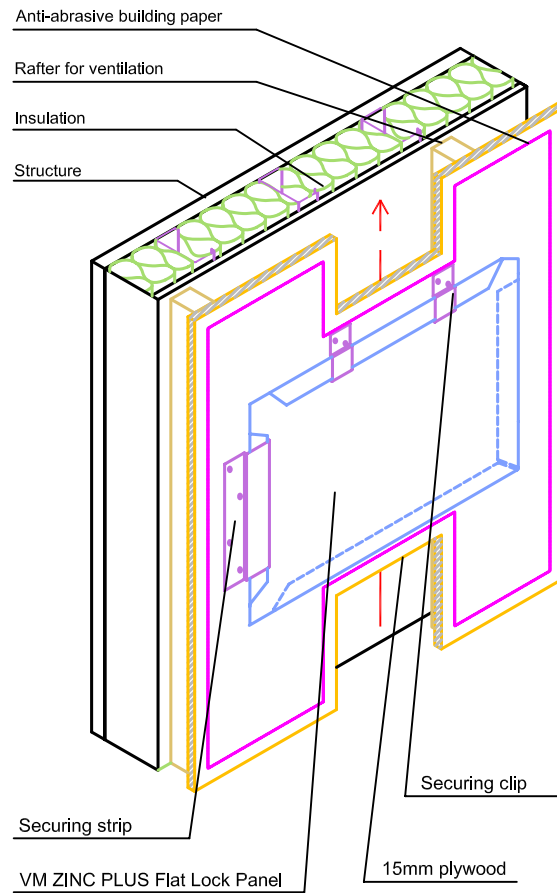

LAYING FRAMEWORK

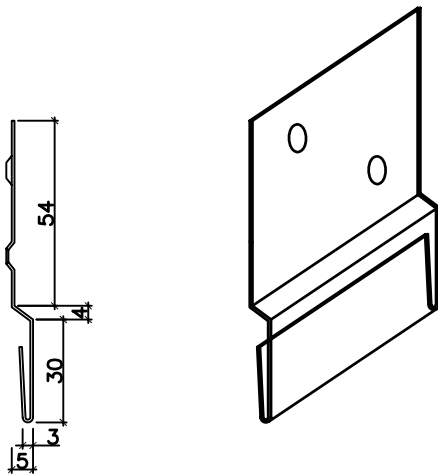

CLIP

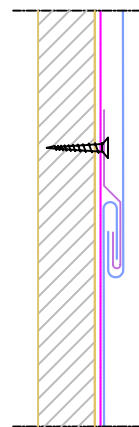

TRANSVERSAL JOINT 1:2

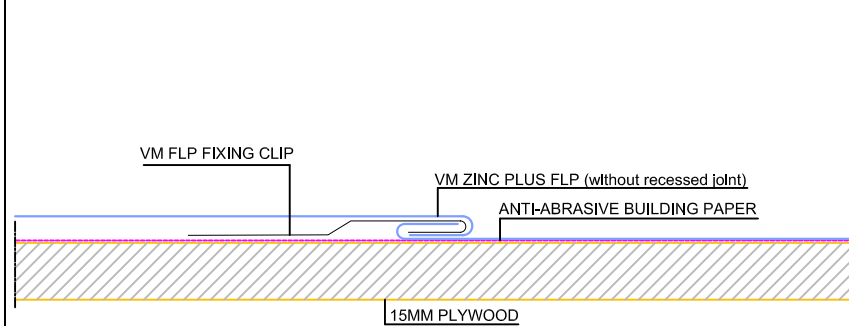

LONGITUDINAL SECTION 1:2

TITLE

TYPICAL DETAIL

System

VM ZINC PLUS® FLAT LOCK
PANEL (Without Recess Joint)

Scale

Varies @ A4

LEGEND:

LEGEND:

Building Products- VM ZINC
PO BOX 727 CROWS NEST
NSW 2065

www.vmzinc.com.au
Tel: (61) 02 9955 4400
Fax: (61) 02 9955 1144

NOT A SHOP DRAWING

FOR ILLUSTRATION ONLY

While all technical information and suggestions herein are believed to be reliable and accurate, nothing stated herein is to be taken as a warranty, expressed or implied. Responsibility for review and validation remains solely with the design authority or other authority having jurisdiction.

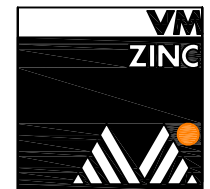

A Umicore brand

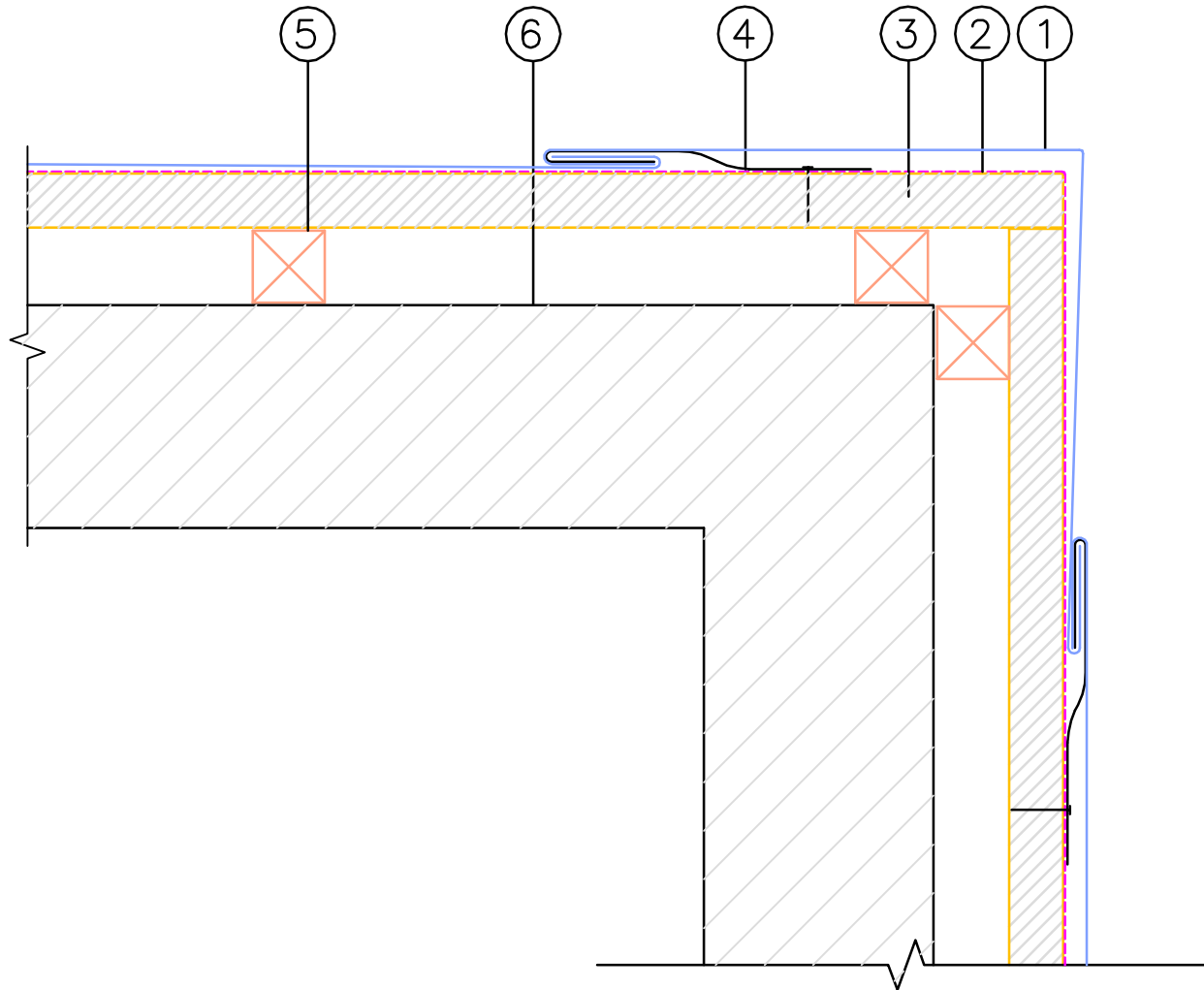

TITLE

EXTERIOR CORNER

System

VM ZINC PLUS® FLAT LOCK
PANEL (Without Recess)

Scale

1:2 @ A4

LEGEND:

LEGEND:

1. VM ZINC PLUS FLP Corner
2. Anti-abrasive building paper
3. 15mm plywood
4. VM ZINC FLP Clip
5. 20mm min Ventilation Gap
6. Main Structure (by others)

Building Products- VM ZINC
PO BOX 727 CROWS NEST
NSW 2065

www.vmzinc.com.au
Tel: (61) 02 9955 4400
Fax: (61) 02 9955 1144

NOT A SHOP DRAWING

FOR ILLUSTRATION ONLY

While all technical information and suggestions herein are believed to be reliable and accurate, nothing stated herein is to be taken as a warranty, expressed or implied. Responsibility for review and validation remains solely with the design authority or other authority having jurisdiction.

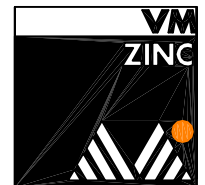

A Umicore brand

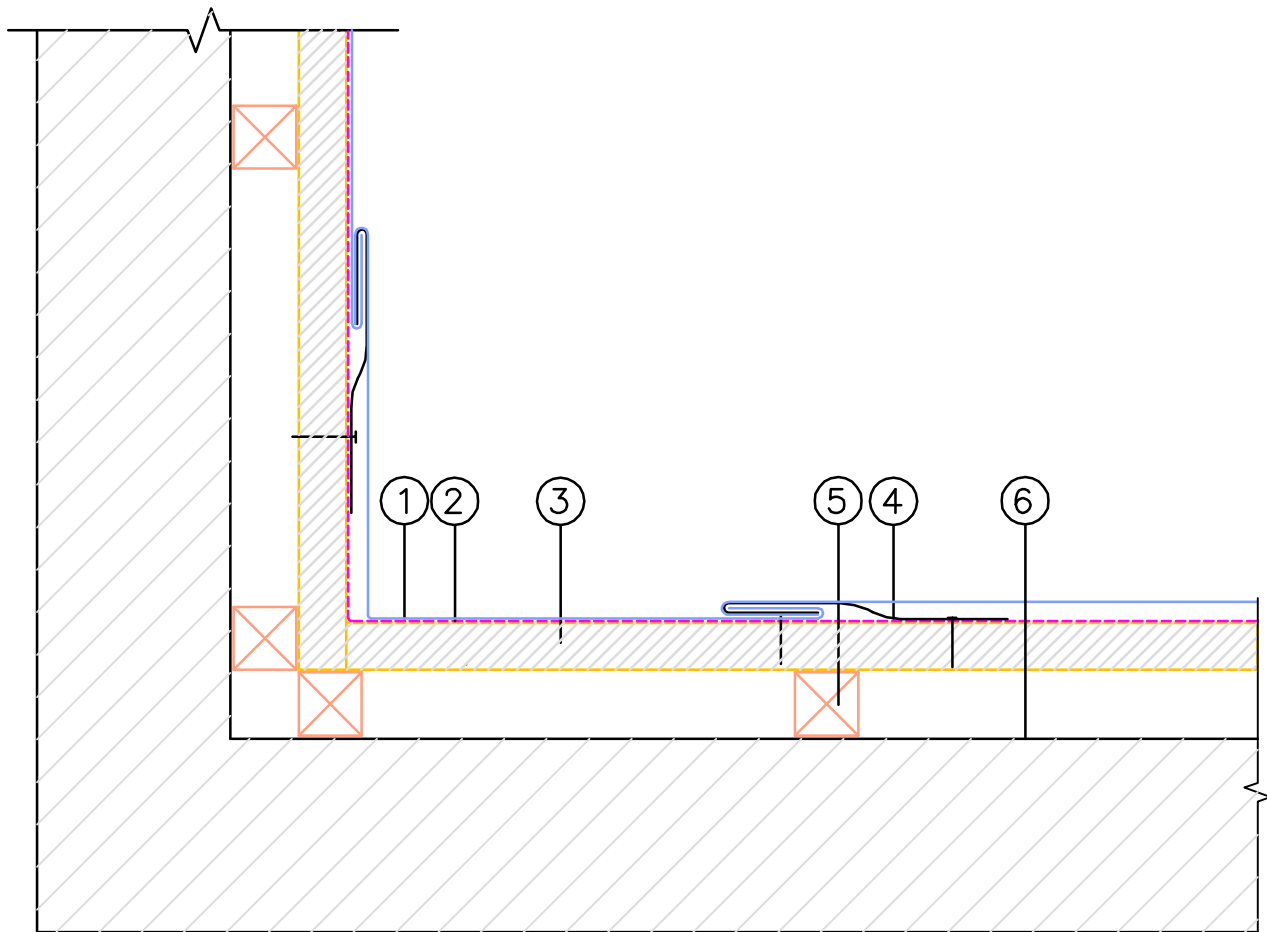

TITLE

SYSTEM

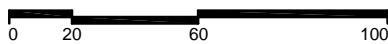

SCALE

INTERIOR CORNER

VM ZINC® FLP lock panel (no recess)

1:2 @A4

LEGEND:

1. VM ZINC PLUS FLP Corner
2. Anti- abrasive building paper
3. 15mm Plywood
4. VM ZINC FLP Clip
5. 20mm min ventilation gap
6. Main Structure (by others)

Building Products- VM ZINC
PO BOX 727 CROWS NEST
NSW 2065

www.vmzinc.com
Tel: (61) 02 9955 4400
Fax: (61) 02 9955 1144

NOT A SHOP DRAWING

FOR ILLUSTRATION ONLY

While all technical information and suggestions herein are believed to be reliable and accurate, nothing stated herein is to be taken as a warranty, expressed or implied. Responsibility for review and validation remains solely with the design authority or other authority having jurisdiction.



A Umicore brand

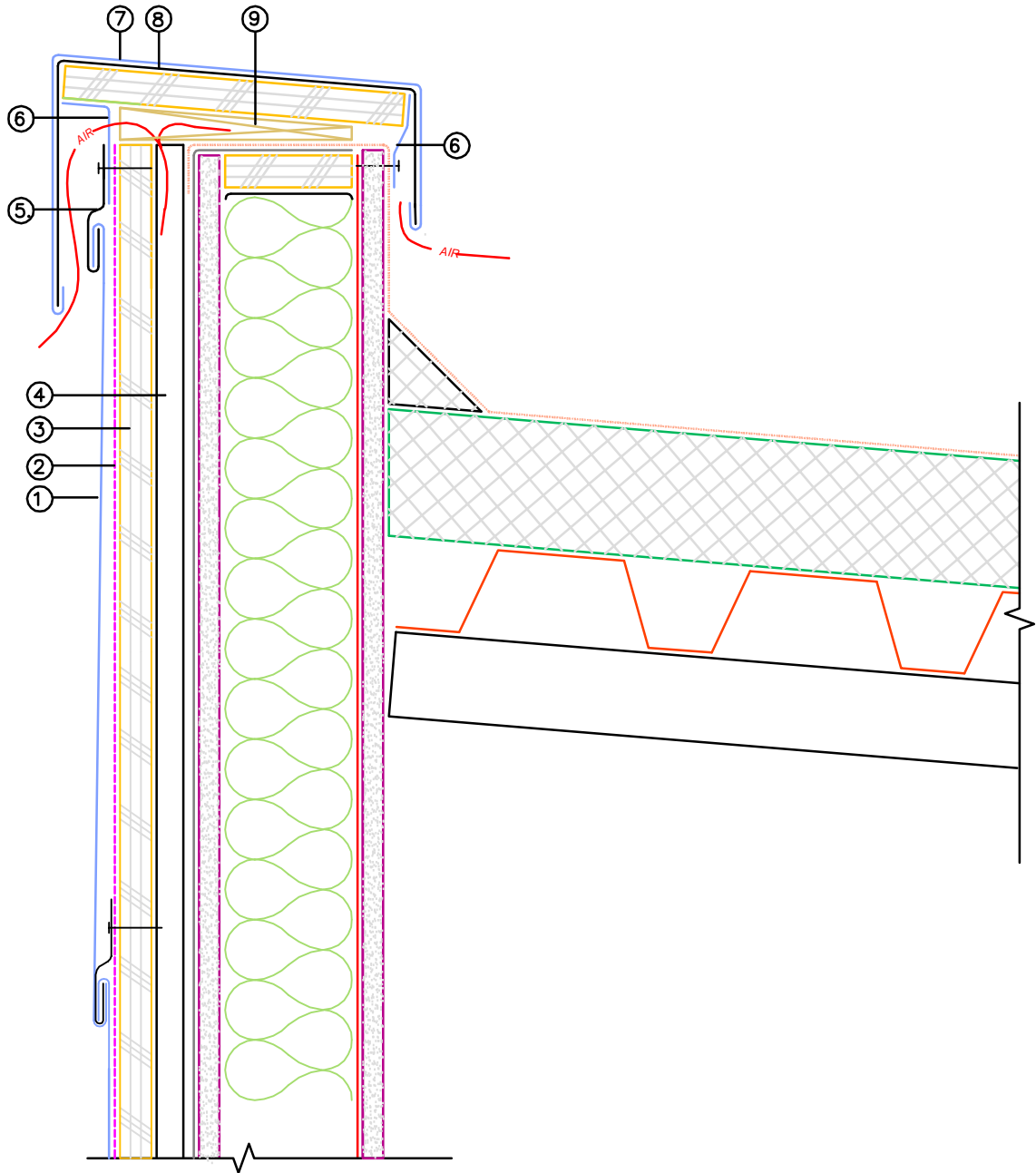

TITLE

SYSTEM

SCALE

PARAPET

VM ZINC® PLUS Flat Lock Panel (no recess)

1:4 @ A4

LEGEND:

1. VM ZINC PLUS flat lock panel
2. Anti-abrasive building paper
3. 15mm plywood
4. 20mm min ventilation gap
5. Galvanised steel clip
6. VM ZINC screen vent @50 % open minimum
7. VM ZINC PLUS parapet capping
8. Continuous galvanised steel stiffener
9. Wood block

Building Products- VM ZINC
PO BOX 727 CROWS NEST
NSW 2065

www.vmzinc.com.au
Tel: (61) 02 9955 4400
Fax: (61) 02 9955 1144

NOT A SHOP DRAWING

FOR ILLUSTRATION ONLY

While all technical information and suggestions herein are believed to be reliable and accurate, nothing stated herein is to be taken as a warranty, expressed or implied. Responsibility for review and validation remains solely with the design authority or other authority having jurisdiction.

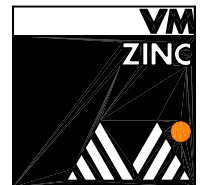

A Umicore brand

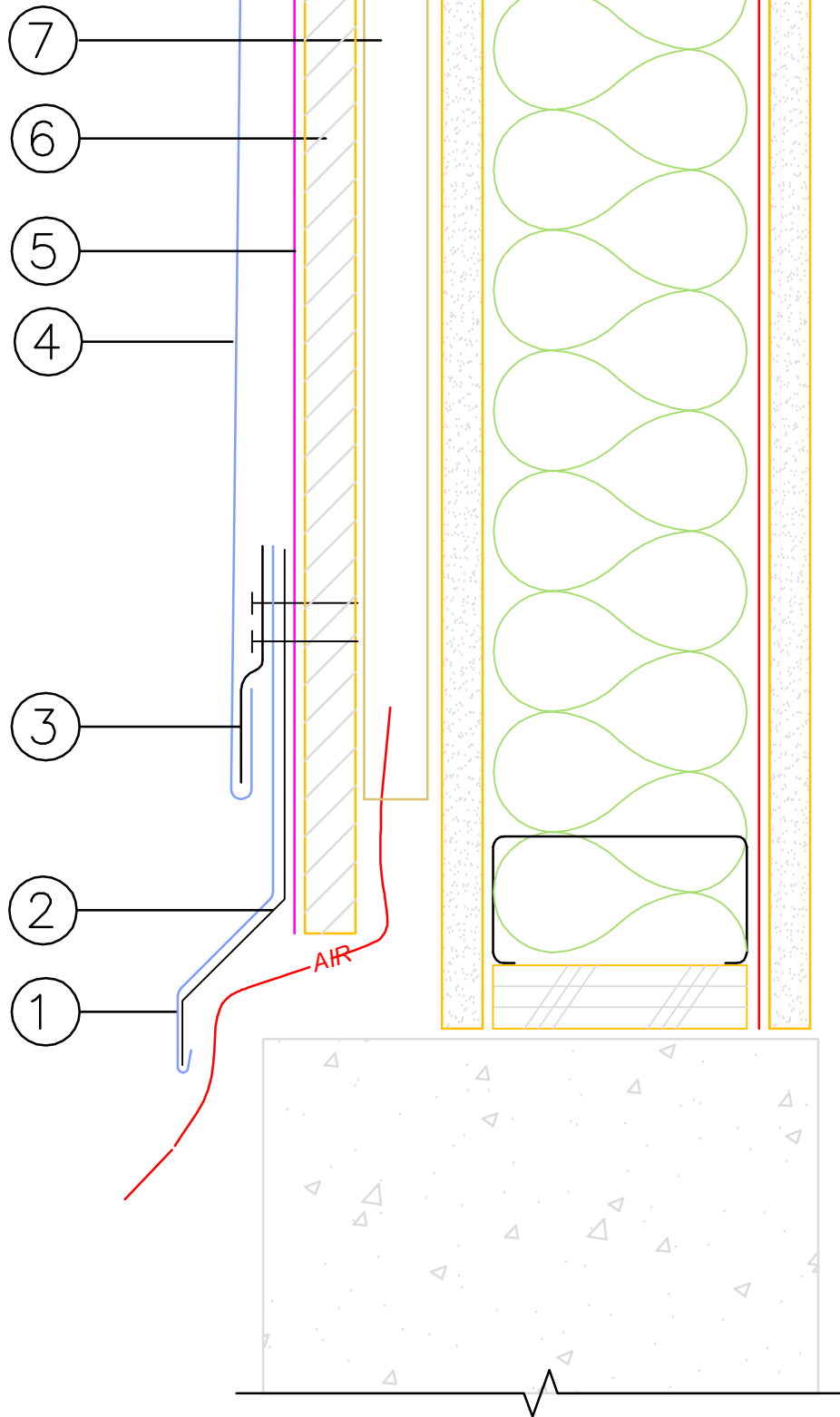

TITLE

SYSTEM

SCALE

Bottom of Wall

VM ZINC® PLUS Vertical Flat Lock Panel (without recessed joint)

1:2 @ A4

LEGEND:

1. VM ZINC PLUS Wall Flashing
2. Galvanised Steel Cleat
3. Fastener
4. VM ZINC Flat lock panel without recess
5. Anti- abrasive building paper
6. 15mm Plywood
7. Ventilation gap 20mm minimum

Building Products- VM ZINC
PO BOX 727 CROWS NEST
NSW 2065

www.vnzinc.com.au
Tel: (61) 02 9955 4400
Fax: (61) 02 9955 1144

NOT A SHOP DRAWING

FOR ILLUSTRATION ONLY

While all technical information and suggestions herein are believed to be reliable and accurate, nothing stated herein is to be taken as a warranty, expressed or implied. Responsibility for review and validation remains solely with the design authority or other authority having jurisdiction.

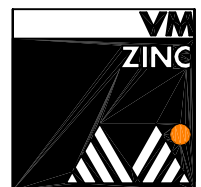

A Umicore brand